

HYCONTROL
LEVEL MEASUREMENT SOLUTIONS



MICROWAVE LEVEL SWITCH

(DC)

HYCMWSST-SR224V

FOR SOLIDS, GRANULES AND POWDERS

MICROWAVE LEVEL SWITCH

This range of microwave level switches provides a simple **non-contact, non-intrusive** option suitable for many applications on powders and solids. An installation comprises a transmitter and a receiver mounted facing one another **up to 40m apart**.

During operation, the transmitter emits a continuous, low power microwave beam to the receiver, and an output relay is energised or de-energised when this beam is obstructed by the material being monitored. The switch trigger point is determined by the amount of microwave energy received. It can therefore be adjusted to cater for different products and different sensitivity settings depending upon the application.

Typical applications for detecting the presence and non-presence of materials include **flow and no-flow conditions, point level detection, blocked chute detection, and proximity switch detection for reversing vehicles such as quarry trucks and rail cars**.



MICROWAVE FEATURES

Non-contact principle: The switches can be installed behind various window materials like Teflon or polypropylene to maintain the integrity of the vessel or chute, even if they need to be removed.

High penetration and surface coating immunity: The microwaves easily penetrate any surface contaminants, making the switches ideal for applications with high build up on the tank or silo walls. This switch is also immune to problems with airborne contaminants such as dust or steam.

Simple installation and set-up: A wide beam angle on the transmitter sensor enables the two sensors' alignment to be carried out easily. The received power level is also indicated by a bank of 15 LEDs which allows a clear visual indication of the state of power received and the location of the switch setpoint (*see opposite*).

Total safety for operators and site personnel: This device requires no special procedures for its operation as power limitations are well below required industry standards.

New heterodyne detection principle: Many older microwave switches employ diode detection technology; Hycontrol switches use the Heterodyne detection principle, which obtains a proportional output to the power received. This increases the operating range and penetrability without increasing the power of the transmitted microwave signal.

Easy retrofit to new and existing tanks: A wide range of flanges and a standard 1" BSPP process thread make this range extremely easy to retrofit to new and old installations utilising existing process connections.

ADVANTAGES AND BENEFITS

- ◆ **Non-contact technology with no moving parts reduces maintenance costs**
- ◆ **Versatile technology for liquids, slurries, solids, pellets and powders**
- ◆ **Long measuring range up to 40m with adjustable sensitivity to suit most applications**
- ◆ **Simple to install and commission, leading to reduced installation costs**
- ◆ **Immune to coatings on tank walls, improving reliability and reducing maintenance costs**
- ◆ **Non-invasive technology, with no long probes to insert, so the internal product build-up is reduced**
- ◆ **Suitable for demanding environments such as corrosive, high dust, high vibration or vapours**
- ◆ **Chemical resistant window options for corrosive applications**

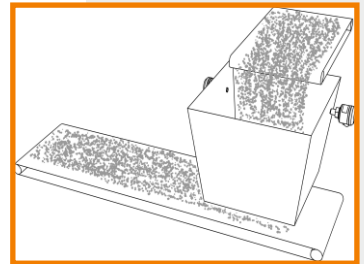

Blocked Chute

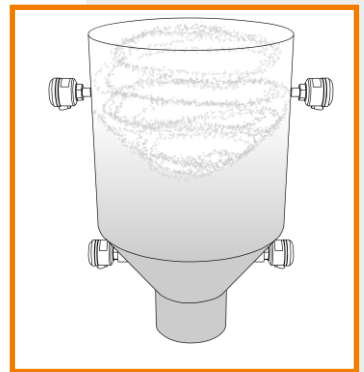

Cyclone Level Switches

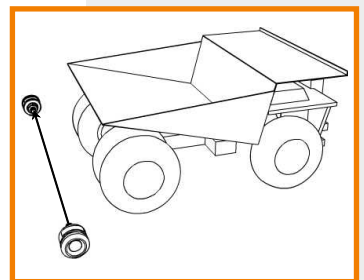

Truck Reversing

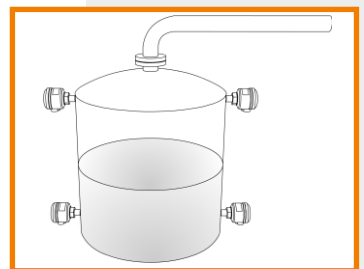

High and Low Level Detection

MICROWAVE LEVEL SWITCH - COMMISSIONING

Simple commissioning with LED adjustment: The sensitivity is adjusted visually using the 15 LED indicator array. The received power level and sensitivity set-point are indicated on the receiver by the LED array. The brightest LED indicates the received power. Then, by a simple adjustment screw, the user can adjust the relay set point (dimmer LED) either way.

This system allows for a very precise visual sensitivity adjustment and greatly simplifies maintenance and commissioning as switch positions and sensitivity are seen at a glance.

See the diagram (right) for a guide to the display head. This is accessed by removing the screw cap.

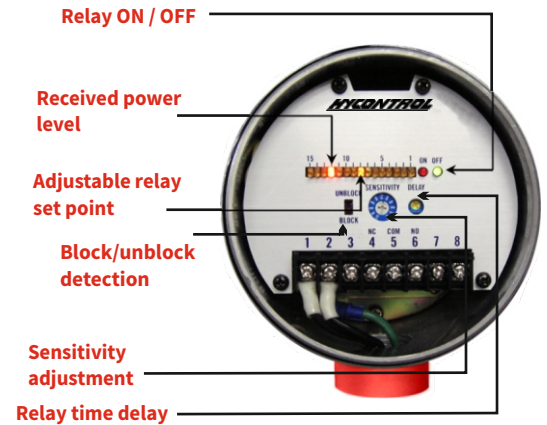

Use isolated, non-invasive mounting for high vibration and hazardous applications: Sensors may be protected from high temperatures, dangerous materials, vibration and shock by installing detecting windows through which the microwaves can pass.

Detecting windows should be made of non-metallic materials such as ceramic, glass, Teflon or polypropylene. With these materials, there is minimal loss of microwave energy between the two sensors.

The detecting windows should be at least 60mm in diameter as microwaves pass more easily through larger apertures. The distance between the window and the sensing face should be less than 200mm.

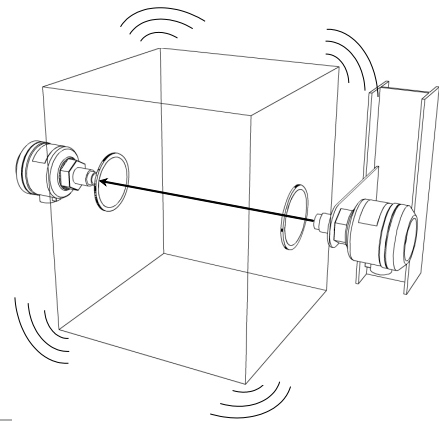

MOUNTING OPTIONS

STANDARD

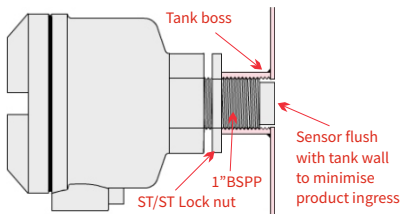

Standard 1" BSPP process connection directly into the tank socket. Suitable for low abrasion applications.

FLANGE

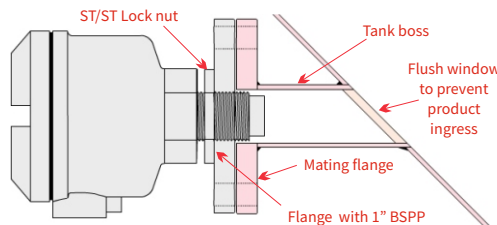

Flange with 1" BSPP process connection through a flange socket with Teflon window. The angle of the tank wall will have little or no effect on the transmitter.

FLANGE WITH INSERT

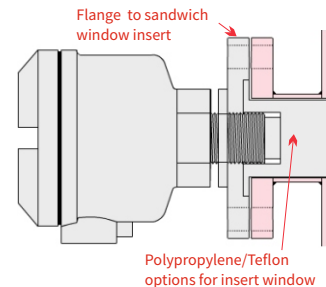

Flange process connection with optional polypropylene plug sandwiched between flanges but flush with tank wall. This provides additional sensor protection.

APPLICATIONS IN MOST MAJOR INDUSTRIES



Quarry

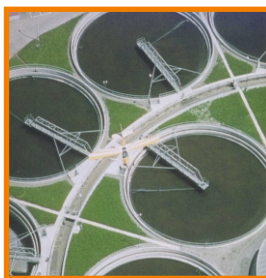

Water & Waste



Process



Chemical



Mining

TECHNICAL SPECIFICATIONS

Model reference HYCMWSST-SR224V comprising:

Transmitter: HYCMWS-ST-2-24V
Receiver: HYCMWS-SR-2-24V

Power supply

Transmitter: 24VDC \pm 10%
Receiver: 24VDC \pm 10%

Power consumption

Transmitter: 1W, 42mA
Receiver: 2W, 83mA

Operating range

Maximum 40 metres
(Note: operating distance may vary depending upon installation)

Frequency & transmission power

Approx. 24GHz, less than 10 mW

Received power level

Indicated by 1 of 15 LEDs
Note: Indicator is fully illuminated

Sensitivity setpoint

Indicated by 1 of 15 LEDs
Note: Indicator is half-illuminated

Beam angle

Approx. 20 degrees (inclusive angle)

Relay contact

1C (SPDT) relay contact 30VDC, 2A

Response time

10 msec

Adjustable time delay

0.1 ~ 10 sec

Delay time from power on to function

Transmitter: Approx. 50 msec
Receiver: Approx. 5 sec

Operating ambient temperature

-10°C ~ +55°C

Option:

Ceramic high temperature extension (300mm)
-50°C ~ +600°C. EK version

Storage ambient temperature

-20°C ~ +70°C

Continuous maximum pressure

5 bar (75psi)

Cable entry

G3/4, M20 or 1/2" NPT

Enclosure rating

IP65 protection

Enclosure construction

Diecast aluminium

Process connection

G1 (1" BSPP)

Weight

Transmitter: 1kg
Receiver: 1kg

Certification Standards

CE & UKCA compliant

TRANSMITTER AND RECEIVER SENSOR DIMENSIONS

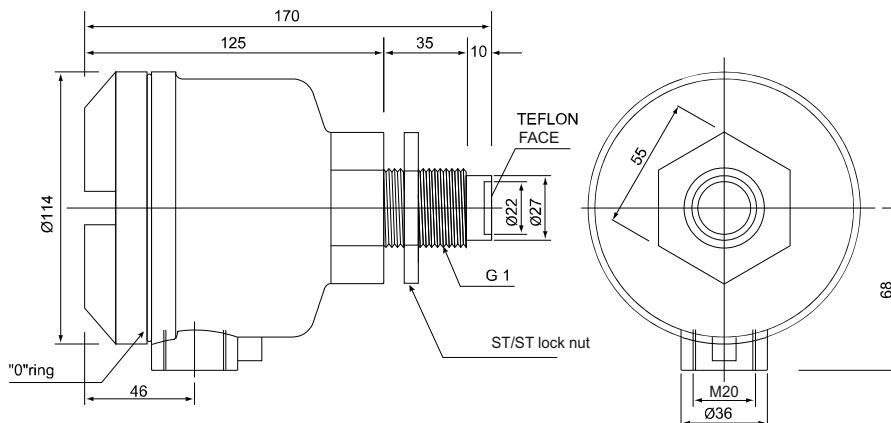

Dimensions may change without prior notice

HYCONTROL - THE COMPLETE LEVEL SOLUTION

Hycontrol has been at the forefront of level control and measurement technology for over thirty-five years, providing effective solutions for diverse applications across a wide range of industries ranging from quarrying to food; from nuclear power to chemical; and from animal feed to waste recycling. From our manufacturing base in Redditch, Worcestershire, we have been trusted to oversee thousands of applications across the UK and around the world.

At Hycontrol, we pride ourselves on providing a 'complete solution' service to our UK customers. We provide a turnkey solution for level equipment requirements, with the experience and skill to design, manufacture, install and maintain bespoke measurement and control systems that are crafted to suit the particular needs of each individual customer.

We understand the consequences of inaccurate or unreliable level systems, and therefore each Hycontrol installation is tailored precisely to match your application. Our goal is simple: to provide the best-engineered solution - *without compromise*.

With one of the widest ranges of level measurement technologies on the market including award-winning silo pressure safety systems and a patented range of foam detection and control equipment, backed up by a team of highly experienced engineers and technicians, Hycontrol is a leading force in the manufacture and supply of advanced level solutions.



Product Range for Solids:

- (1) TDR radar
- (2) 80 GHz FMCW radar
- (3) 2-wire ultrasonic transmitter
- (4) RF admittance level switch
- (5) 24 GHz FMCW radar
- (6) Vibrating level probe
- (7) Rotary paddle switch
- (8) Capacitance level switch
- (9) Microwave flow & blockage switch

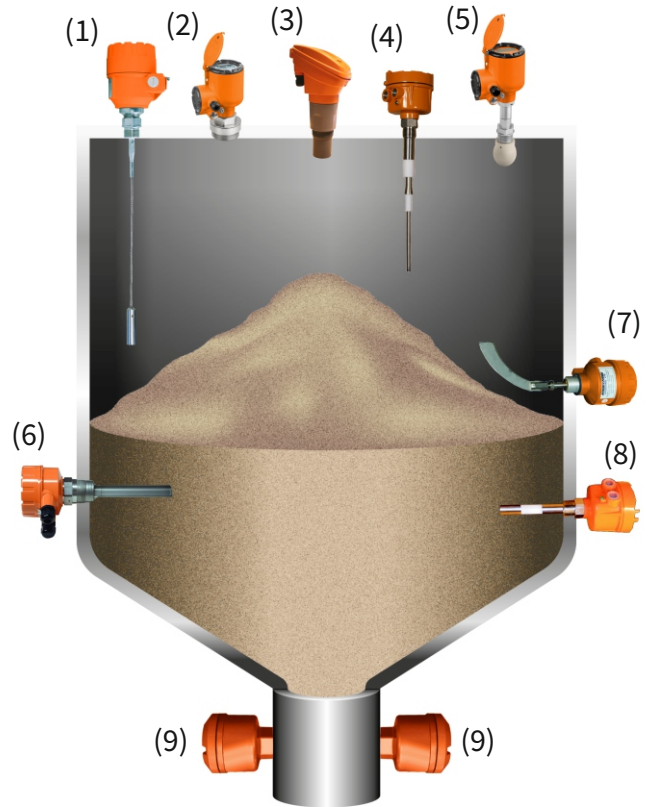

Product Range for Liquids:

- (1) Bypass level indicator
- (2) 80 GHz FMCW radar
- (3) Foam control system
- (4) 24 GHz FMCW radar
- (5) 2-wire ultrasonic transmitter
- (6) TDR radar
- (7) Capacitance level switch
- (8) RF admittance level switch
- (9) Tuning fork vibrating level switch

